

Product Specification Sheet

2630

RoHS Compliant 1.25Gbps 850nm Optical Transceiver 550m Reach



Product Features

- Supports 1.25Gbps/1.0625Gbps bit rates
- Duplex LC connector
- Hot pluggable SFP footprint
- 850nm VSCSEL laser transmitter and PIN photo-detector
- Applicable for 550m on 50/125 μ m, 300m on 62.5/125 μ m MMF connection
- Low power consumption, < 0.5W
- Digital Diagnostic Monitor Interface
- Compliant with SFP MSA and SFF-8472
- Very low EMI and excellent ESD protection
- Operating case temperature:
 - Industrial:-40 to 85 °C



Applications

- Gigabit Ethernet
- Fiber Channel
- Switch to Switch interface
- Switched backplane applications
- Router/Server interface
- Other optical transmission systems

Product Descriptions

The 2630, The SFP transceivers are high performance, cost effective modules supporting data-rate of 1.25Gbps and 550m transmission distance with MMF. The transceiver consists of three sections: a VCSEL laser transmitter, a PIN photodiode integrated with a trans-impedance preamplifier (TIA) and MCU control unit. All modules satisfy class I laser safety requirements. The transceivers are compatible with SFP Multi-Source Agreement (MSA) and SFF-8472. For further information, please refer to SFP MSA.

Functional Diagram

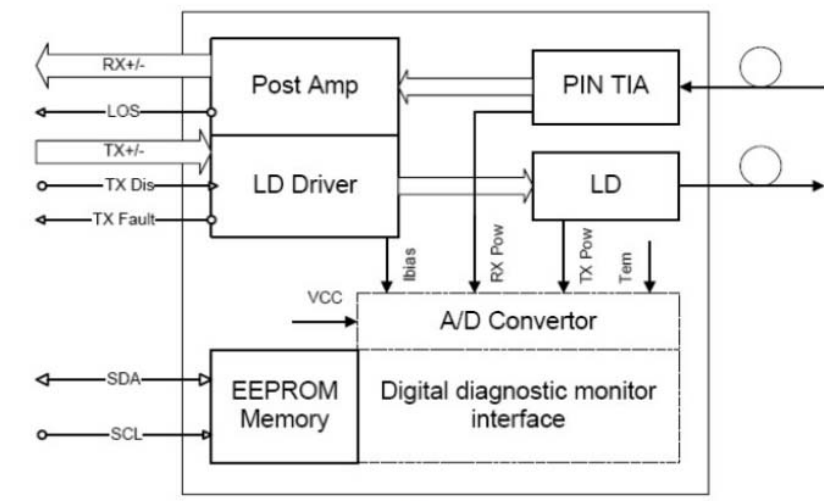

Absolute Maximum Ratings

Parameter	Symbol	Min.	Max.	Unit	Note
Supply Voltage	Vcc	-0.5	4.0	V	
Storage Temperature	Ts	-40	85	°C	
Relative Humidity	RH	0	85	%	

Note: Stress in excess of the maximum absolute ratings can cause permanent damage to the transceiver.

General Operating Characteristics

Parameter	Symbol	Min.	Typ	Max.	Unit	Note
Data Rate	DR	1.0625	1.25		Gb/s	
Supply Voltage	Vcc	3.13	3.3	3.47	V	
Supply Current	Icc _s			144	mA	
Operating Case Temp.	Tc	0		70	°C	
	Tl	-40		85		



Electrical Characteristics (T_{OP(C)} = -40 to 85 °C, V_{CC} = 3.13 to 3.47 V)

Parameter	Symbol	Min.	Typ	Max.	Unit	Note
Transmitter						
Differential data input swing	V _{IN,PP}	250		1200	mVpp	1
Tx Disable Input-High	V _{IH}	2.0		V _{CC} +0.3	V	
Tx Disable Input-Low	V _{IL}	0		0.8	V	
Tx Fault Output-High	V _{OH}	2.0		V _{CC} +0.3	V	2
Tx Fault Output-Low	V _{OL}	0		0.8	V	2
Input differential impedance	R _{in}		100		Ω	
Receiver						
Differential data output swing	V _{out,pp}	250		550	mVpp	3
Rx LOS Output-High	V _{ROH}	2.0		V _{CC} +0.3	V	2
Rx LOS Output-Low	V _{ROL}	0		0.8	V	2

Notes:

1. TD+/- are internally AC coupled with 100Ω differential termination inside the module.
2. Tx Fault and Rx LOS are open collector outputs, which should be pulled up with 4.7k to 10kΩ resistors on the host board. Pull up voltage between 2.0V and V_{CC}+0.3V.
3. RD+/- outputs are internally AC coupled, and should be terminated with 100Ω (differential) at the user SERDES.

Optical Characteristics (T_{OP(C)} = -40 to 85 °C, V_{CC} = 3.13 to 3.47 V)

Parameter	Symbol	Min.	Typ	Max.	Unit	Note
Transmitter						
Operating Wavelength	λ	840	850	860	nm	
Ave. output power (Enabled)	P _{AVE}	-10		-3	dBm	1
Extinction Ratio	ER	9			dB	1
RMS spectral width	Δλ			0.65	nm	
Rise/Fall time (20%~80%)	T _r /T _f			0.25	ps	2
Output Optical Eye	Compliant with IEEE802.3 z & ITU G.957 Compliant (class 1 user safety)					
Receiver						
Operating Wavelength	λ	840	850	860	nm	
Receiver Sensitivity	P _{SEN1}			-18	dBm	3
Overload	P _{AVE}	-3			dBm	3
LOS Assert	P _a	-35			dBm	
LOS De-assert	P _d			-20	dBm	
LOS Hysteresis	P _d -P _a	0.5			dB	

Notes:

1. Measured at 1250 Mb/s with PRBS 2²³⁻¹ NRZ test pattern.
2. Unfiltered, measured with a PRBS 2²³⁻¹ test pattern @1250Mbps
3. Measured at 1250 Mb/s with PRBS 2²³⁻¹ NRZ test pattern for BER < 1x10⁻¹⁰

Pin Definition And Functions

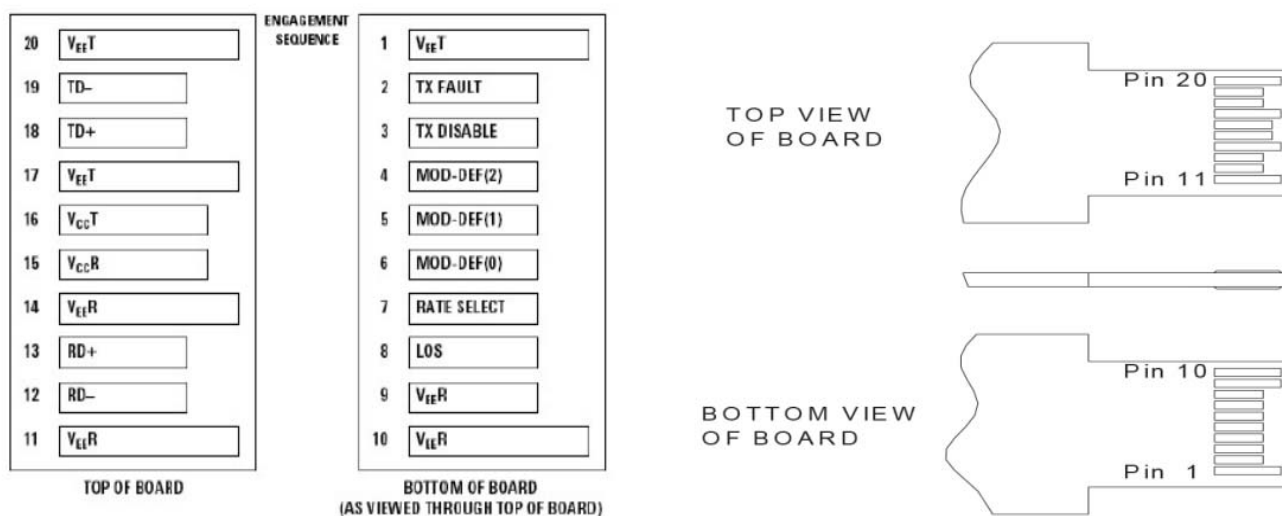

Pin	Symbol	Name/Description	Notes
1	V _{EE} T	Tx ground	
2	Tx Fault	Tx fault indication, Open Collector Output, active “H”	1
3	Tx Disable	LVTTTL Input, internal pull-up, Tx disabled on “H”	2
4	MOD-DEF2	2 wire serial interface data input/output (SDA)	3
5	MOD-DEF1	2 wire serial interface clock input (SCL)	3
6	MOD-DEF0	Model present indication	3
7	Rate select	No connection	
8	LOS	Rx loss of signal, Open Collector Output, active “H”	4
9	V _{EE} R	Rx ground	
10	V _{EE} R	Rx ground	
11	V _{EE} R	Rx ground	
12	RD-	Inverse received data out	5
13	RD+	Received data out	5
14	V _{EE} R	Rx ground	
15	V _{CC} R	Rx power supply	
16	V _{CC} T	Tx power supply	
17	V _{EE} T	Tx ground	
18	TD+	Transmit data in	6
19	TD-	Inverse transmit data in	6
20	V _{EE} T	Tx ground	

Notes:

1. When high, this output indicates a laser fault of some kind. Low indicates normal operation. And should be pulled up with a 4.7 – 10KΩ resistor on the host board.
2. TX disable is an input that is used to shut down the transmitter optical output. It is pulled up within the module with a 4.7 – 10KΩ resistor. Its states are:

Low (0 – 0.8V): Transmitter on (>0.8, < 2.0V): Undefined
 High (2.0V~Vcc+0.3V): Transmitter Disabled Open: Transmitter Disabled



3.Mod-Def 0,1,2. These are the module definition pins. They should be pulled up with a 4.7K – 10KΩ resistor on the host board. The pull-up voltage shall be between 2.0V~Vcc+0.3V.

Mod-Def 0 has been grounded by the module to indicate that the module is present

Mod-Def 1 is the clock line of two wire serial interface for serial ID

Mod-Def 2 is the data line of two wire serial interface for serial ID

4.When high, this output indicates loss of signal (LOS). Low indicates normal operation.

5.RD+/-: These are the differential receiver outputs. They are AC coupled 100Ω differential lines which should be terminated with 100Ω (differential) at the user SERDES. The AC coupling is done inside the module and is thus not required on the host board.

6. TD+/-: These are the differential transmitter inputs. They are AC-coupled, differential lines with 100Ω differential termination inside the module. The AC coupling is done inside the module and is thus not required on the host board.

Digital Diagnostic Specifications

The 2630 transceivers can be used in host systems that require either internally or externally calibrated digital diagnostics.

Parameter	Symbol	Units	Min.	Max.	Accuracy	Note
Transceiver temperature	DTemp-E	°C	-45	+90	±5°C	1
Transceiver supply voltage	DVoltage	V	2.8	4.0	±3%	
Transmitter bias current	DBias	mA	2	15	±10%	2
Transmitter output power	DTx-Power	dBm	-13	0	±3dB	
Receiver average input power	DRx-Power	dBm	-21	0	±3dB	

Notes:

1. When Operating temp.=0~70 °C, the range will be min=-5, Max=+75
2. The accuracy of the Tx bias current is 10% of the actual current from the laser driver to the laser
3. Internal/ External Calibration compatible.

Typical Interface Circuit

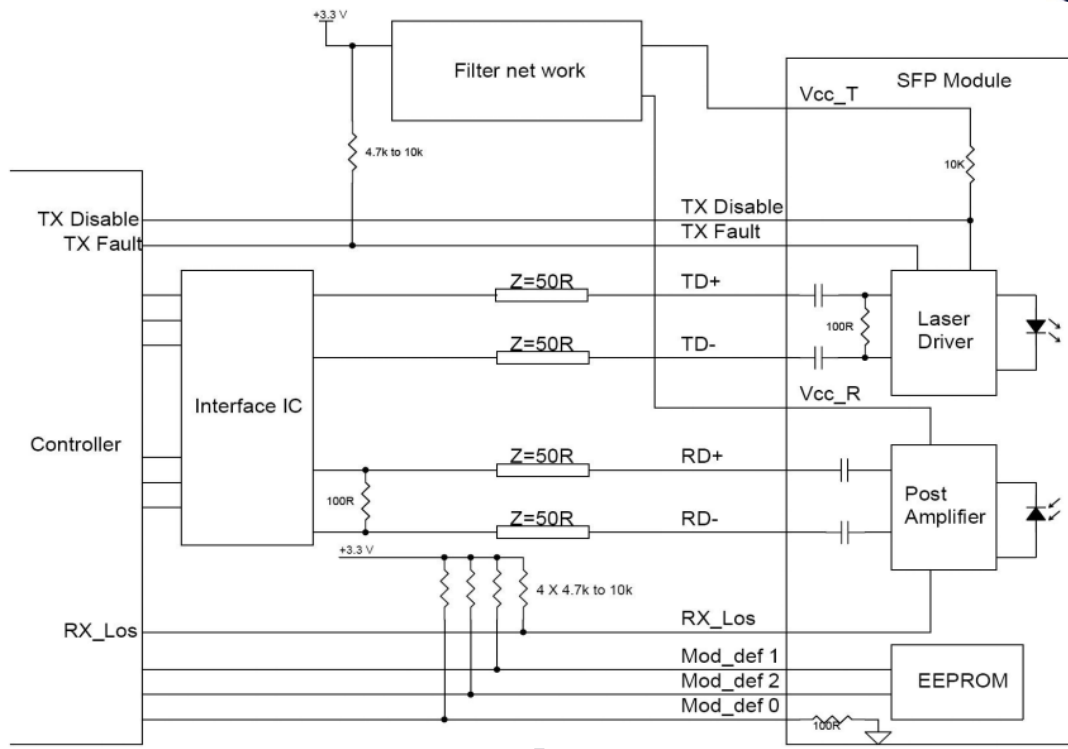

Package Dimensions

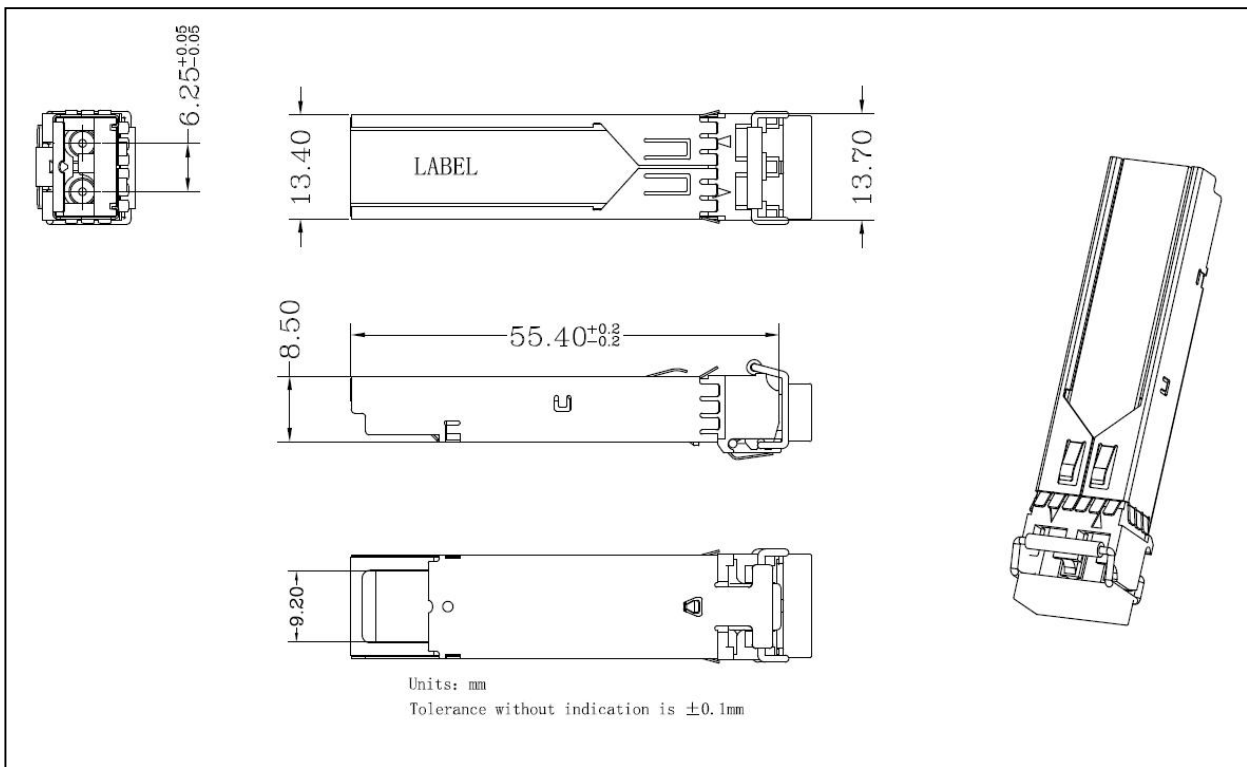

Ordering Information



Part Number	Description
2630	SFP,1.25Gbps, 850nm, Multimode,550m, 0~70°C, with DDM